

56-01 dummy support



product description

The 56-01 dummy support provides an economic means to create a tank or vessel weighing system.

In three-legged vessels, it is possible to use two 56-01 supports and just one weigh module and still obtain accurate weight data for level control. Alternatively, two units can be incorporated into four-legged vessel when using two weigh modules.

The 56-01 dummy supports have the same height as 52-13 weigh modules (56-01-13 version) respective, the 52-18 weigh modules (56-01-18 version) and can be combined at corresponding capacities.

The supports are dimensioned to take side forces in any horizontal direction as well as lift off forces, up to 100% of maximum capacity. The weigh module can therefore be of simplest free sliding type and fitted with lift off protection only if required. If foundation plates and tank feet are prepared also with mounting holes for the weigh module, the scale can later easily be upgraded to a high accuracy load cell system by replacing the dummy supports with weigh modules.

applications

Tank and vessel level control systems.

key features

Height compatible with 52-13 and 52-18 weigh modules

Zinc plated mild steel or stainless steel

Allows for thermal expansion/contraction

Capacities up to 100kN

Easy installation by bolting or welding

Tolerates large angular errors for tank foot and foundation plate

Very rugged design

accessories

Welding plates top and /or bottom



product dimensions (mm)

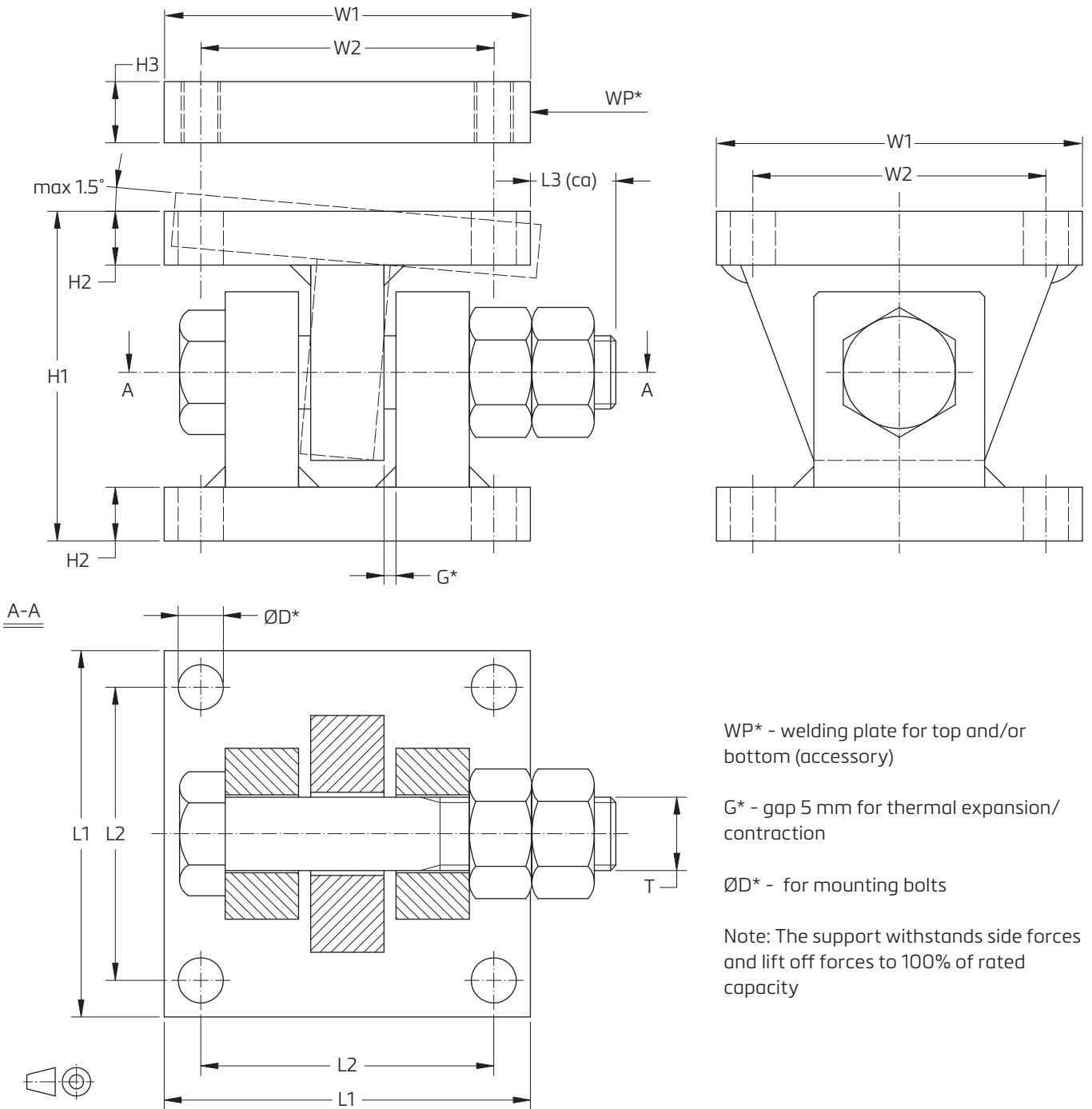

Version	Capacity	H1	H2	H3	L1	L2	L3	W1	W2	T	D	Mounting bolts
56-01-13 (compatible with 52-13)	20 kN (2039 kg) / 5 klb (2268 kg)	75	10	15	100	80	28	100	80	M20	10	M8 8.8
	50 kN (5099 kg)	110	18	20	120	94	35	120	94	M24	14.5	M12 8.8
	100 kN (10179 kg)	135	22	25	150	120	35	150	120	M30	18.5	M16 8.8
56-01-18 (compatible with 52-18)	20 kN (2039 kg) / 5 klb (2268 kg)	100	10	15	100	80	38	80	58	M20	9	M8 8.8
	50 kN (5099 kg)	135	18	20	100	76	48	100	76	M24	11	M10 8.8
	100 kN (10179 kg)	195	22	25	120	90	48	120	90	M30	13,5	M12 8.8

CAD files for customer's own application drawings are available for download from the Flintec homepage.

orientation of dummy support

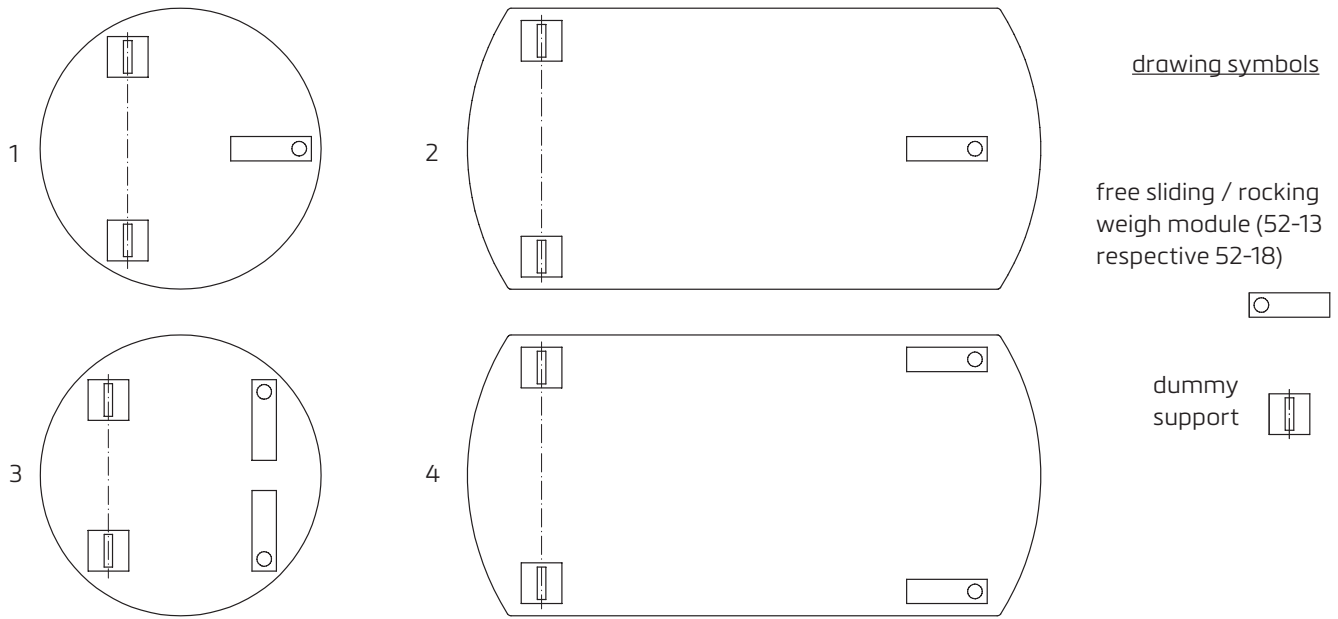

Specifications and dimensions are subject to change without notice.